

# Sno-King

## Instruction Manual

### Model #1888



Model #1888

# Safety Precautions



## ⚠ CAUTION

This equipment is designed and sold for commercial use only. This equipment is not to be used by the consumer in home use. Do not allow direct contact of this equipment by the public when used in food service locations. Only personnel trained and experienced in the equipment operation may operate this equipment.  
Carefully read all installation instructions before operating the equipment.



## ⚠ WARNING

Always wear safety glasses when servicing this equipment.



## ⚠ WARNING

Never put your fingers or any object into the shaver body (the goose-neck) while the motor is running. Serious injury may occur. *(Gold Medal Products does not assume any liability for injury due to careless handling and/or reckless operation of this equipment).*



## ⚠ WARNING

Any alterations to this equipment will void the warranty and may cause a dangerous situation. NEVER make alterations to the equipment.



## ⚠ DANGER

Machine must be properly grounded to prevent electrical shock to personnel.

Do NOT immerse the equipment in water.

Always unplug the equipment before cleaning or servicing.

## NOTE

The information, specifications and illustrations contained in this manual represent the latest data available at time of publication. Right is reserved to make changes as required at the discretion of Gold Medal Products Company without notice.

---

# INSTALLATION

## MACHINE DESCRIPTION

The Sno-King is an automatic shaver with a tremendous capacity. You will find that it keeps up with any demand. The Sno-King consists of the hopper, which houses the cutter head, the pusher handle, the motor, and the display case.

## ELECTRICAL REQUIREMENTS

The Sno-King operates on 120 Volt, 15 Amp, single phase, 60 cycle AC current. Be sure that your electrical supply meets this requirement.

## ICE REQUIREMENTS

The Sno-King can take ice cubes or block ice, if you break the block into pieces approximately 3 to 4 inches in size.

**NOTE:** The ice will not enter the shaving chute if the pieces are too large.

# MACHINE OPERATION

Plug the power cord into the appropriate electrical outlet.

## TO OPERATE THE SNO-KING

1. Fill the hopper to within an inch of the top with ice cubes or block ice (no larger than 3" to 4"). The larger the pieces, the better the snow.
2. Toggle the **POWER** switch to the **ON** position.
3. While pushing the **MOTOR** switch, apply downward pressure to the pusher handle. Apply firm and even pressure to make the best snow. Practice will allow you to gauge when to stop pressing. This allows the ice to resettle against the shaver head. Too much pressure will result in snow that is coarse; too little pressure will make the snow mushy.

**NOTE:** Never allow any foreign or metallic objects around the shaver area of the Sno-King. Ice picks, scoops, and debris that may be in the ice often damage blades.

## MAINTENANCE INSTRUCTIONS



### CAUTION

THE FOLLOWING SECTIONS OF THIS MANUAL ARE INTENDED ONLY FOR QUALIFIED SERVICE PERSONNEL WHO ARE FAMILIAR WITH ELECTRICAL EQUIPMENT. THESE ARE NOT INTENDED FOR THE OPERATOR.



### WARNING

Adequate eye protection must be used when servicing this equipment to prevent the possibility of injury.



### DANGER

Do NOT immerse the equipment in water.  
Unplug your machine before servicing.

## ORDERING SPARE PARTS

1. Identify the desired part by checking it against the photos, illustrations, and/or the parts list.
2. When ordering, please include part number, part name, and quantity desired.
3. Please include your model name and machine serial number (located on the machine nameplate) with your order.
4. Address all parts orders to:

Parts Department  
Gold Medal Products Co.  
10700 Medallion Drive  
Cincinnati, Ohio 45241-4807  
or, place orders at:  
(513) 769-7676  
Fax: (513) 769-8500  
E-mail: [goldme19@eos.net](mailto:goldme19@eos.net)

## INSTALLING NEW SHAVER BLADES

Inspect your equipment before replacing the blades. With the **POWER** switch **OFF**, use a flashlight to examine the blades in the shaver body. If the blades appear to be nicked or bent, then the blades should be replaced.

Follow this procedure:

1. Unplug the main power supply cord from the electrical outlet.
2. Remove the shaver head from the motor shaft by loosening the Allen head set screws between the motor and the hopper.
3. Remove the shaver head. Pull the shaver head off of the motor shaft and through the hopper. If the shaver head is frozen onto the shaft, remove the hold down bolts on the motor. Pull the motor back, trapping the shaver head against the inside of the hopper, until the shaver head disengages.
4. After removing the shaver head, check the motor shaft for burrs and corrosion. Use a fine tooth file to remove the burrs and corrosion.
5. Remove the blades from the shaver head. These blades may be re-sharpened, but it is far better to replace the old blades with a new set.
6. Position the new blades and insert screws until they are finger tight.
7. Set the blade thickness equal to a dime. (See illustration below.) Make sure that the height is even across the shaver head.
8. Tighten the blade screws completely. Check the blades again with a dime to ensure the blades did not move while tightening the screws.
9. Replace the motor and shaver head. Mount the motor using the hold down bolts. Insert the shaver head through the hopper and onto the motor shaft. Press the shaver head onto the motor shaft with the pusher handle, then move the shaver head in another 1/8". Check that the shaver head is not rubbing against the back of the hopper and the blades are not touching the pusher handle.
10. Replace the set screws between the hopper and the motor.

**NOTE:** Replace any shims that were between the motor base and the mounting surface.

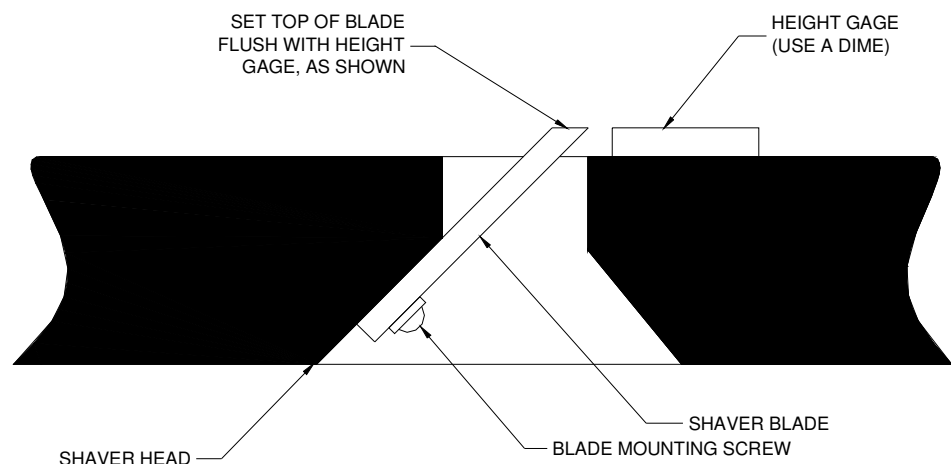



# #1888 ASSEMBLY

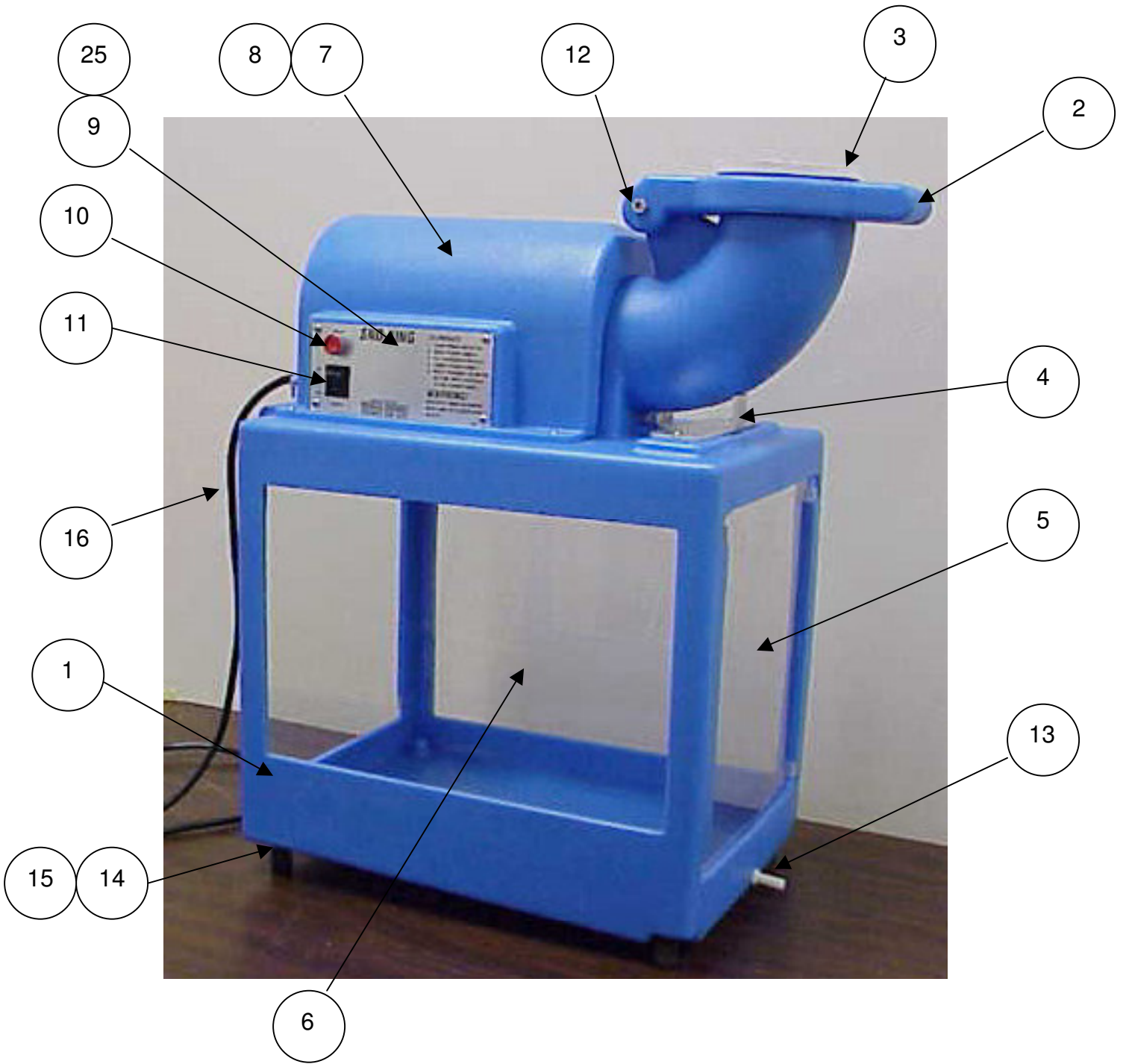

# #1888 ASSEMBLY





# SHAVER HEAD

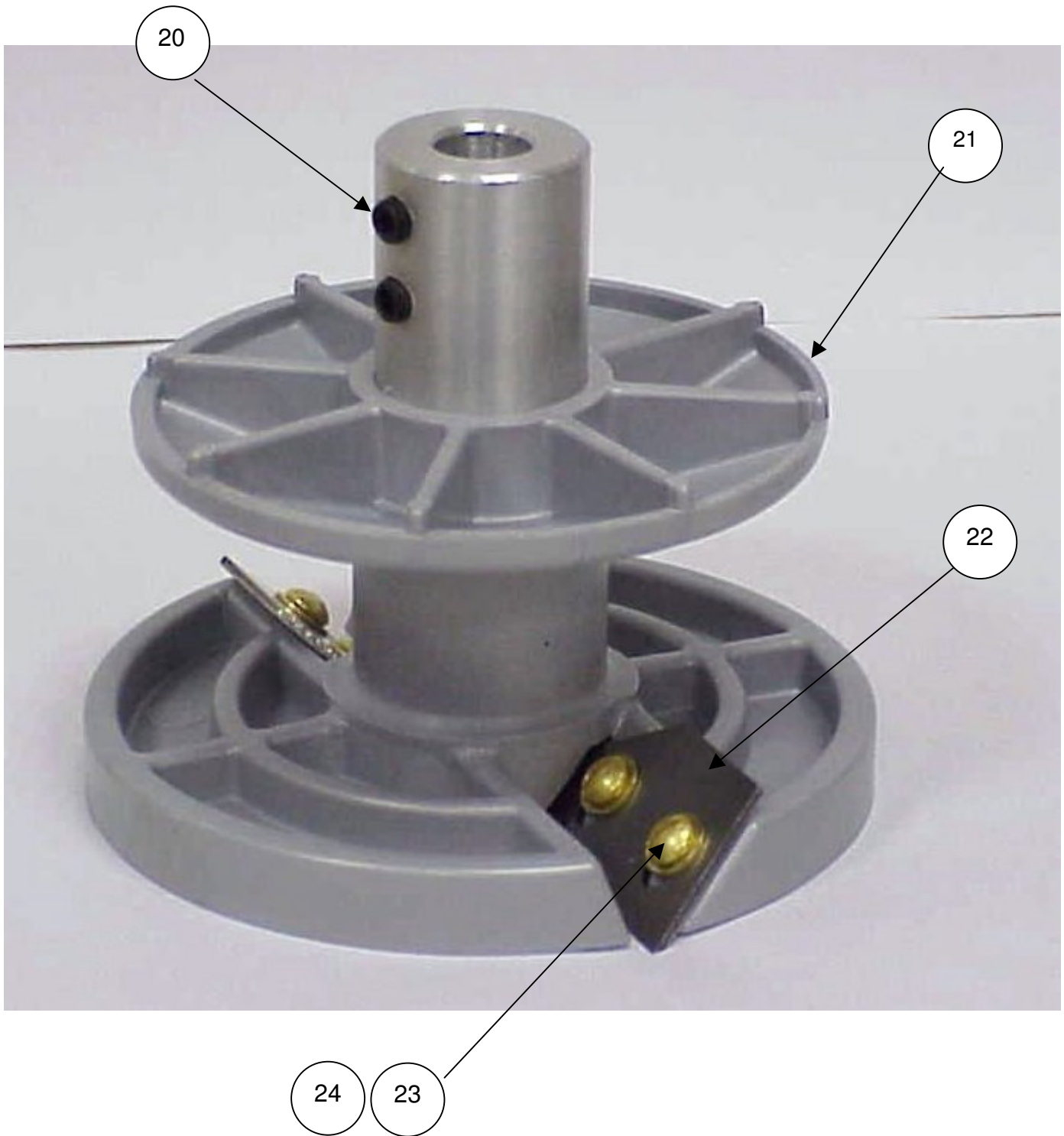

## PARTS LIST

Model # 1888		
Item No.	Part No.	Description
1	12660	Shaver Body
2	12662	Plunger
3	12671	Pusher Cap
4	12667	Neck Bracket
5	12663	Side Panel
6	12664	Front Panel
7	12661	Motor Cover
8	12456	Motor - Drive
9	12665	Name/Switch Plate
10	38971	Momentary Switch
11	42798	Switch, Lighted Rocker
12	12670	Pivot Rod
13	12668	Drain Fitting
14	49656	Glide
15	49123	Crutch Tip
16	22038	Lead-in Cord 15 Amp Plug
17	74746	3 inch Fan Grate
18	12673	Plate, Power Cord
19	44073	Strain Relief
20	74125	Set Screw 1/4-20 x 3/8
21	22015NM	Shaver Head
22	22018	2 Hole Blade
23	12018	Blade Mtg Screw Brass
24	12073	#8 Brass Washer
25	12672	Wire Enclosure
26		
27		
28		
29		
30		
31		
32		
33		
34		
35		

\*\* The replacement kit includes two blades, the screws and washers, and the warnin

# ELECTRICAL SCHEMATIC MODEL #1888

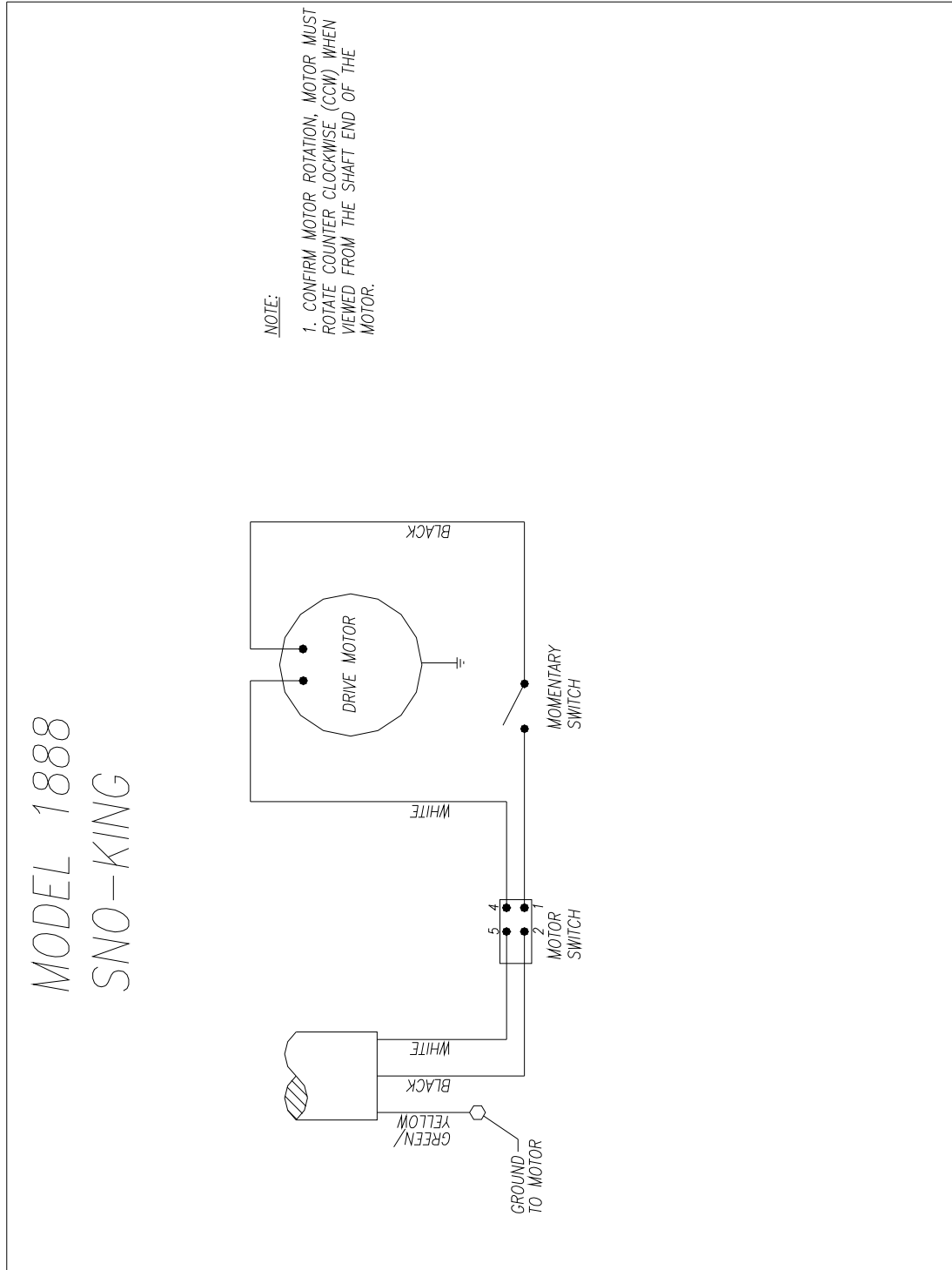

## WARRANTY

WE WARRANT to the original purchaser the Gold Medal equipment sold by us to be free from defects in material or workmanship under normal use and service. Our obligation under this warranty shall be limited to the repair or replacement of any defective part for a period of six (6) months from the date of sale to the Original Purchaser with regard to labor and two (2) years with regard to parts and does not cover damage to the equipment caused by accident, alteration, improper use, voltage, abuse, or failure to follow instructions.

THIS WARRANTY IS IN LIEU OF ALL OTHER WARRANTIES EXPRESSED OR IMPLIED, AND OF ALL OTHER OBLIGATIONS OR LIABILITIES ON OUR PART, INCLUDING THE IMPLIED WARRANTY OF MERCHANTABILITY. THERE ARE NO WARRANTIES WHICH EXTEND BEYOND THE DESCRIPTION ON THE FACE HEREOF. We neither assume, nor authorize any other person to assume for us, any other obligation or liability in connection with the sale of said GOLD MEDAL equipment or any part thereof.

The term "Original Purchaser" as used in this warranty shall be deemed to mean that person, firm, association, or corporation who was billed by the GOLD MEDAL PRODUCTS COMPANY, or their authorized distributor for the equipment.

THIS WARRANTY HAS NO EFFECT AND IS VOID UNLESS THE ORIGINAL PURCHASER FIRST CALLS GOLD MEDAL PRODUCTS COMPANY AT 1-800-543-0862 TO DISCUSS WITH OUR SERVICE REPRESENTATIVE THE EQUIPMENT PROBLEM, AND, IF NECESSARY, FOR INSTRUCTIONS CONCERNING THE REPAIR OR REPLACEMENT OF PARTS.

*NOTE: This equipment is manufactured and sold for commercial use only.*



**GOLD MEDAL PRODUCTS COMPANY**  
**10700 Medallion Drive**  
**Cincinnati, Ohio 45241-4807 USA**